

HTD® Taper Bore

5mm Pitch 5M-15 (15mm Wide Belt)

Product Description	Number of Teeth	Type	Bush Size	Dp	De	Df	Dm	Di	F	S	Weight kgf
34-5M-15	34	S3F	1008	54.11	53	57	43	-	21	22	0.19
36-5M-15	36	S3F	1108	57.30	56	60	44	-	21	22	0.20
38-5M-15	38	S3F	1108	60.48	59	66	48	-	21	22	0.25
40-5M-15	40	S3F	1108	63.66	63	71	52	-	21	22	0.31
44-5M-15	44	S3F	1108	70.03	69	75	54	-	21	22	0.40
48-5M-15	48	S3F	1210	76.39	75	83	64	-	21	25	0.45
56-5M-15	56	S3F	1210	89.13	88	93	70	-	21	25	0.67
64-5M-15	64	S3F	1210	101.86	101	106	78	-	21	25	0.96
72-5M-15	72	S3F	1610	114.59	113	119	90	-	21	25	1.19
80-5M-15	80	S3F	1610	127.32	126	135	92	-	21	25	1.57
90-5M-15	90	A1	1610	143.24	142	-	92	126	21	25	1.47
112-5M-15	112	A1	1610	178.25	177	-	92	162	21	25	1.94
136-5M-15	136	A1	2012	216.45	215	-	106	199	21	32	3.06
150-5M-15	150	A1	2012	238.73	238	-	106	222	21	32	3.90

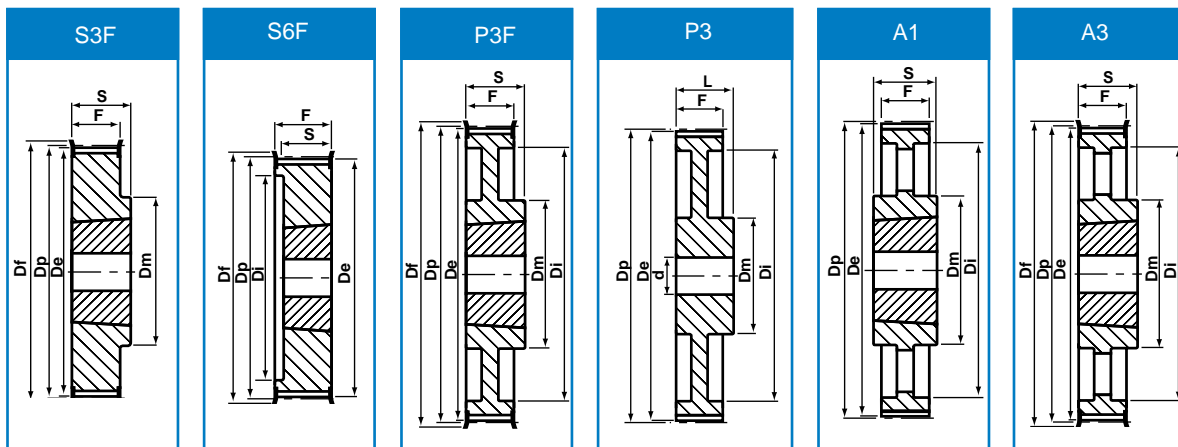

8mm Pitch 8M-20 (20mm Wide Belt)

Product Description	Number of Teeth	Type	Bush Size	Dp	De	Df	Dm	Di	F	S	Weight kgf
22-8M-20	22	S6F	1008	56.02	55	60	-	41	28	22	0.24
24-8M-20	24	S6F	1108	61.12	60	66	-	42	28	22	0.30
26-8M-20	26	S6F	1108	66.21	65	71	-	46	28	22	0.36
28-8M-20	28	S6F	1108	71.30	70	75	-	50	28	22	0.44
30-8M-20	30	S6F	1108	76.39	75	83	-	58	28	22	0.53
32-8M-20	32	S6F	1610	81.49	80	87	-	62	28	25	0.42
34-8M-20	34	S6F	1610	86.58	85	91	-	65	28	25	0.55
36-8M-20	36	S6F	1610	91.67	90	91	-	68	28	25	0.68
38-8M-20	38	S6F	1610	96.77	95	103	-	72	28	25	0.80
40-8M-20	40	S6F	1610	101.86	100	106	-	76	28	25	1.00
44-8M-20	44	S3F	2012	112.05	111	119	93	-	28	32	1.20
48-8M-20	48	S3F	2012	122.23	121	127	96	-	28	32	1.60
56-8M-20	56	S3F	2012	142.60	141	148	110	-	28	32	2.40
64-8M-20	64	P3F	2012	162.97	162	168	110	137	28	32	2.70
72-8M-20	72	P3F	2012	183.35	182	192	110	158	28	32	3.30
80-8M-20	80	P3	2012	203.72	202	-	110	180	28	32	3.50
90-8M-20	90	A3	2012	229.18	228	-	110	204	28	32	3.65
112-8M-20	112	A3	2517	285.21	284	-	125	260	28	45	6.20
144-8M-20	144	A3	2517	366.69	365	-	125	341	28	45	9.00
168-8M-20	168	A1	3525	427.81	426	-	190	402	28	65	16.40
192-8M-20	192	A1	3525	488.92	488	-	190	460	28	65	21.80

Every effort has been taken to ensure that the data listed in this catalogue is correct. Challenge accepts no liability for any inaccuracies or damage caused. All dimensions in millimetres unless otherwise stated.

HTD® Taper Bore

8mm Pitch 8M-30 (30mm Wide Belt)

Product Description	Number of Teeth	Type	Bush Size	Dp	De	Df	Dm	Di	F	S	Weight kgf
22-8M-30	22	S6F	1008	56.02	55	60	-	41	38	22	0.24
24-8M-30	24	S6F	1108	61.12	60	66	-	42	38	22	0.38
26-8M-30	26	S6F	1108	66.21	65	71	-	46	38	22	0.45
28-8M-30	28	S6F	1108	71.30	70	75	-	50	38	22	0.50
30-8M-30	30	S0F	1615	76.39	75	83	-	-	38	-	0.55
32-8M-30	32	S0F	1615	81.49	80	87	-	-	38	-	0.59
34-8M-30	34	S0F	1615	86.58	85	91	-	-	38	-	0.77
36-8M-30	36	S0F	1615	91.67	90	91	-	-	38	-	0.96
38-8M-30	38	S0F	1615	96.77	95	103	-	-	38	-	1.15
40-8M-30	40	S0F	1615	101.86	100	106	-	-	38	-	1.34
44-8M-30	44	S2F	2012	112.05	111	119	-	91	38	32	1.33
48-8M-30	48	S2F	2012	122.23	121	127	-	95	38	32	1.78
56-8M-30	56	S2F	2012	142.60	141	148	-	117	38	32	3.76
64-8M-30	64	S3F	2517	162.97	162	168	125	-	38	45	4.20
72-8M-30	72	P3F	2517	183.35	182	192	125	158	38	45	4.30
80-8M-30	80	P3	2517	203.72	202	-	125	180	38	45	4.60
90-8M-30	90	A3	2517	229.18	228	-	125	204	38	45	5.00
112-8M-30	112	A3	2517	285.21	284	-	125	260	38	45	6.20
144-8M-30	144	A3	2517	366.69	365	-	125	341	38	45	9.00

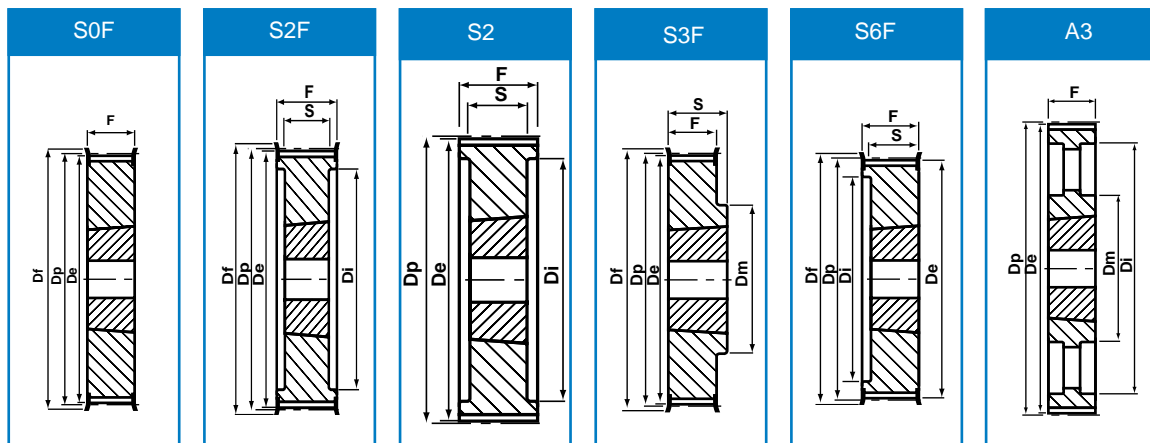

8mm Pitch 8M-50 (50mm Wide Belt)

Product Description	Number of Teeth	Type	Bush Size	Dp	De	Df	Dm	Di	F	S	Weight kgf
28-8M-50	28	S6F	1210	71.30	70	75	-	50	60	25	0.60
30-8M-50	30	S6F	1615	76.39	75	83	-	58	60	38	0.65
32-8M-50	32	S6F	1615	81.49	80	87	-	62	60	38	0.82
34-8M-50	34	S6F	1615	86.58	85	91	-	65	60	38	1.10
36-8M-50	36	S6F	1615	91.67	90	99	-	68	60	38	1.30
38-8M-50	38	S6F	1615	96.77	95	103	-	72	60	38	1.60
40-8M-50	40	S2F	2012	101.86	100	106	-	82	60	32	1.71
44-8M-50	44	S2F	2012	112.05	111	119	-	91	60	32	1.78
48-8M-50	48	S2F	2012	122.23	121	127	-	96	60	32	2.30
56-8M-50	56	S2F	2517	142.60	141	148	-	116	60	45	3.40
64-8M-50	64	S2F	2517	162.97	162	168	-	137	60	45	5.00
72-8M-50	72	S2F	2517	183.35	182	192	125	158	60	45	6.70
80-8M-50	80	S2	3020	203.72	202	-	-	180	60	51	8.80
90-8M-50	90	P2	3020	229.18	228	-	170	204	60	51	10.00
112-8M-50	112	P2	3020	285.21	284	-	170	260	60	51	12.00
144-8M-50	144	A2	3020	366.69	365	-	170	341	60	51	15.20
168-8M-50	168	A1	3525	427.81	426	-	190	402	60	65	16.40
192-8M-50	192	A1	3525	488.92	488	-	190	460	60	65	21.80

All dimensions in millimetres unless otherwise stated. Every effort has been taken to ensure that the data listed in this catalogue is correct. Challenge accepts no liability for any inaccuracies or damage caused

HTD® Taper Bore

8mm Pitch 8M-85 (85mm Wide Belt)

Product Description	Number of Teeth	Type	Bush Size	Dp	De	Df	Dm	Di	F	S	Weight kgf
34-8M-85	34	S2F	1615	86.58	85	91	-	65	95	38	1.43
36-8M-85	36	S2F	1615	91.67	90	98	-	68	95	38	1.87
38-8M-85	38	S2F	1615	96.77	95	103	-	72	95	38	2.20
40-8M-85	40	S2F	2012	101.86	100	106	-	82	95	32	1.80
44-8M-85	44	S2F	2012	112.05	111	119	-	91	95	32	2.30
48-8M-85	48	S2F	2517	122.23	121	127	-	100	95	45	2.66
56-8M-85	56	S2F	2517	142.60	141	148	-	117	95	45	4.45
64-8M-85	64	S2F	2517	162.97	162	168	-	137	95	45	6.20
72-8M-85	72	S2F	3020	183.35	182	192	-	158	95	51	8.00
80-8M-85	80	S2	3020	203.72	202	-	-	180	95	51	10.00
90-8M-85	90	P2	3020	229.18	228	-	170	204	95	51	10.80
112-8M-85	112	P2	3020	285.21	284	-	170	260	95	51	15.00
144-8M-85	144	A2	3525	366.69	365	-	190	341	95	65	20.00
168-8M-85	168	A2	3525	427.81	426	-	190	402	95	65	23.00
192-8M-85	192	A2	3525	488.92	488	-	190	460	95	65	28.50

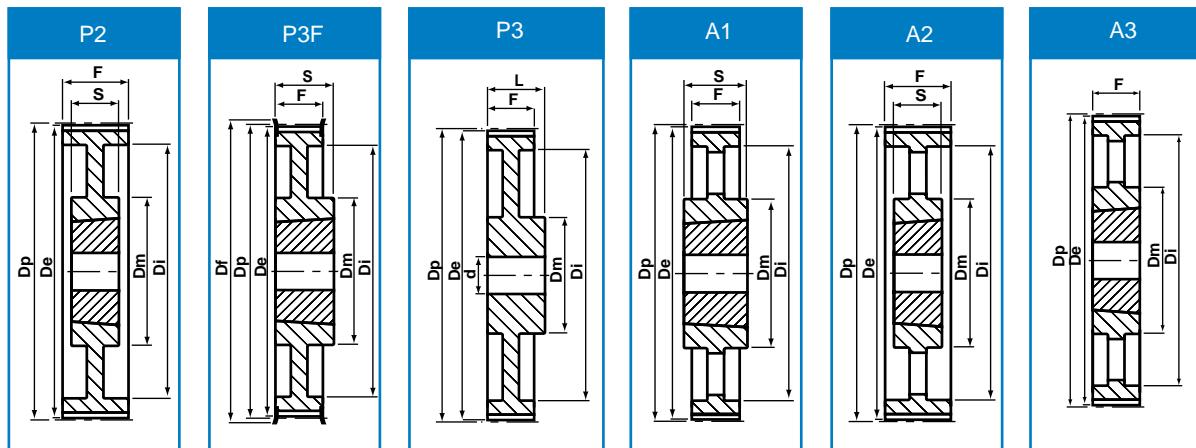

14mm Pitch 14M-40 (40mm Wide Belt)

Product Description	Number of Teeth	Type	Bush Size	Dp	De	Df	Dm	Di	F	S	Weight kgf
28-14M-40	28	S2F	2012	124.78	122	127	-	98	54	32	2.10
29-14M-40	29	S2F	2012	129.23	127	138	-	100	54	32	2.38
30-14M-40	30	S2F	2012	133.69	131	138	-	100	54	32	2.65
32-14M-40	32	S2F	2012	142.60	140	154	-	104	54	32	3.40
34-14M-40	34	S2F	2517	151.52	149	160	-	110	54	45	3.87
36-14M-40	36	S2F	2517	160.43	158	168	-	120	54	45	4.80
38-14M-40	38	S2F	2517	169.34	167	183	-	130	54	45	5.40
40-14M-40	40	S2F	2517	178.28	175	188	-	138	54	45	6.00
44-14M-40	44	S2F	3020	196.08	193	211	-	155	54	51	7.80
48-14M-40	48	S2F	3020	213.90	211	226	-	170	54	51	9.40
56-14M-40	56	P2F	3020	249.55	247	256	170	208	54	51	10.10
64-14M-40	64	P2F	3020	285.21	282	296	170	242	54	51	13.40
72-14M-40	72	P2	3020	320.86	318	-	170	280	54	51	15.20
80-14M-40	80	A2	3020	356.51	354	-	170	315	54	51	16.00
90-14M-40	90	A2	3020	401.07	398	-	170	360	54	51	17.80
112-14M-40	112	A2	3020	499.11	496	-	170	457	54	51	25.60
144-14M-40	144	A2	3020	641.71	639	-	170	600	54	51	32.00
168-14M-40	168	A2	3020	748.66	746	-	170	706	54	51	44.00
192-14M-40	192	A2	3020	855.62	853	-	170	813	54	51	49.00
216-14M-40	216	A2	3020	962.57	960	-	170	920	54	51	55.00

HTD[®] Taper Bore

14mm Pitch 14M-55 (55mm Wide Belt)

Product Description	Number of Teeth	Type	Bush Size	Dp	De	Df	Dm	Di	F	S	Weight kgf
28-14M-55	28	S2F	2012	124.78	122	127	-	98	70	32	2.20
29-14M-55	29	S2F	2012	129.23	127	138	-	100	70	32	2.74
30-14M-55	30	S2F	2517	133.69	131	138	-	100	70	45	2.70
32-14M-55	32	S2F	2517	142.60	140	154	-	108	70	45	3.66
34-14M-55	34	S2F	2517	151.52	149	160	-	110	70	45	4.55
36-14M-55	36	S2F	2517	160.43	158	168	-	120	70	45	5.20
38-14M-55	38	S2F	2517	169.34	167	183	-	130	70	45	6.20
40-14M-55	40	S2F	2517	178.25	175	188	-	138	70	45	7.00
44-14M-55	44	S2F	3020	196.08	193	211	-	155	70	51	8.60
48-14M-55	48	S2F	3020	213.90	211	226	-	170	70	51	10.40
56-14M-55	56	P2F	3020	249.55	247	256	170	208	70	51	12.00
64-14M-55	64	P2F	3020	285.21	282	296	170	242	70	51	14.50
72-14M-55	72	P2	3020	320.86	318	-	170	280	70	51	16.20
80-14M-55	80	A2	3020	356.51	354	-	170	315	70	51	17.50
90-14M-55	90	A2	3020	401.07	398	-	170	360	70	51	20.10
112-14M-55	112	A2	3020	499.11	496	-	170	457	70	51	28.40
144-14M-55	144	A2	3020	641.71	634	-	170	600	70	51	36.20
168-14M-55	168	A2	3020	748.66	746	-	170	706	70	51	49.00
192-14M-55	192	A2	3020	855.62	853	-	170	813	70	51	53.00
216-14M-55	216	A1	3535	962.57	960	-	190	920	70	89	65.90

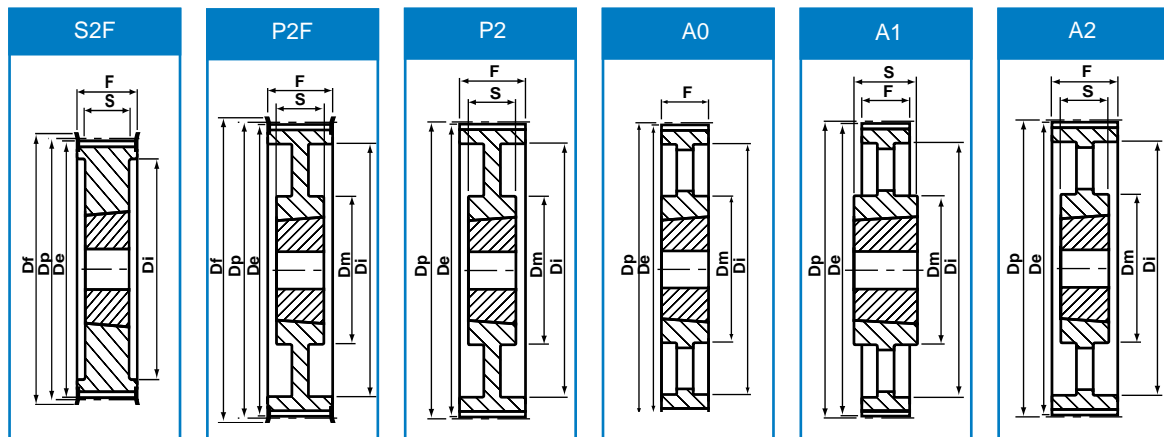

14mm Pitch 14M-85 (85mm Wide Belt)

Product Description	Number of Teeth	Type	Bush Size	Dp	De	Df	Dm	Di	F	S	Weight kgf
28-14M-85	28	S2F	2517	124.78	122	127	-	98	102	45	2.70
29-14M-85	29	S2F	2517	129.23	127	138	-	100	102	45	3.40
30-14M-85	30	S2F	2517	133.69	131	138	-	100	102	45	3.75
32-14M-85	32	S2F	2517	142.60	140	154	-	108	102	45	4.80
34-14M-85	34	S2F	2517	151.52	149	160	-	110	102	45	6.00
36-14M-85	36	S2F	3020	160.43	158	168	-	125	102	51	5.80
38-14M-85	38	S2F	3020	169.34	167	183	-	130	102	51	6.80
40-14M-85	40	S2F	3020	178.25	175	188	-	138	102	51	8.00
44-14M-85	44	S2F	3030	196.08	193	211	-	155	102	76	11.80
48-14M-85	48	S2F	3030	213.90	211	226	-	170	102	76	15.10
56-14M-85	56	S2F	3535	249.55	247	256	190	210	102	89	18.00
64-14M-85	64	P2F	3535	285.21	282	296	190	242	102	89	23.00
72-14M-85	72	P2	3535	320.86	318	-	190	280	102	89	25.00
80-14M-85	80	A2	3535	356.51	354	-	190	315	102	89	26.00
90-14M-85	90	A2	3535	401.07	398	-	190	360	102	89	28.00
112-14M-85	112	A2	3535	499.11	496	-	190	457	102	89	36.50
144-14M-85	144	A2	3535	641.71	639	-	190	600	102	89	48.00
168-14M-85	168	A2	3535	748.66	746	-	190	706	102	89	60.00
192-14M-85	192	A0	4040	855.62	853	-	230	813	102	102	86.00
216-14M-85	216	A0	4040	962.57	960	-	230	920	102	102	91.50

All dimensions in millimetres unless otherwise stated. Every effort has been taken to ensure that the data listed in this catalogue is correct. Challenge accepts no liability for any inaccuracies or damage caused

HTD® Taper Bore

14mm Pitch 14M-115 (115mm Wide Belt)

Product Description	Number of Teeth	Type	Bush Size	Dp	De	Df	Dm	Di	F	S	Weight kgf
28-14M-115	28	S2F	2517	124.78	122	127	-	98	133	45	3.70
29-14M-115	29	S2F	2517	129.23	127	138	-	100	133	45	4.00
30-14M-115	30	S2F	2517	133.69	131	138	-	100	133	45	5.00
32-14M-115	32	S2F	2517	142.60	140	154	-	108	133	45	6.80
34-14M-115	34	S2F	2517	151.52	149	160	-	110	133	45	6.80
36-14M-115	36	S2F	3020	160.43	158	168	-	125	133	51	7.00
38-14M-115	38	S2F	3020	169.34	167	183	-	130	133	51	8.40
40-14M-115	40	S2F	3020	178.25	175	188	-	140	133	51	9.20
44-14M-115	44	S2F	3030	196.08	193	211	-	155	133	76	14.00
48-14M-115	48	S2F	3030	213.90	211	226	-	170	133	76	17.10
56-14M-115	56	S2F	3535	249.55	247	265	-	210	133	89	24.80
64-14M-115	64	P2F	3535	285.21	282	296	190	242	133	89	27.00
72-14M-115	72	P2	3535	320.86	318	-	190	280	133	89	29.00
80-14M-115	80	A2	3535	356.51	354	-	190	315	133	89	32.00
90-14M-115	90	A2	3535	401.07	398	-	190	360	133	89	36.50
112-14M-115	112	A2	3535	499.11	497	-	190	457	133	89	46.00
144-14M-115	144	A2	4040	641.71	639	-	230	600	133	102	68.00
168-14M-115	168	A2	4040	748.66	746	-	230	706	133	102	82.60
192-14M-115	192	A2	4040	855.62	853	-	230	813	133	102	96.00
216-14M-115	216	A2	4040	962.57	960	-	230	920	133	102	107.00

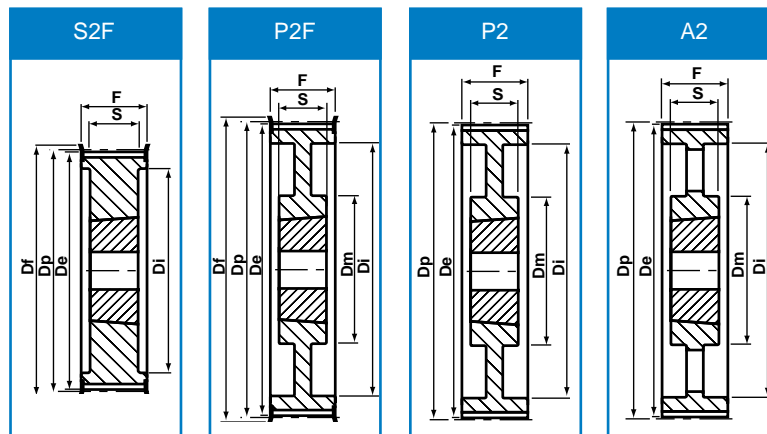

14mm Pitch 14M-170 (170mm Wide Belt)

Product Description	Number of Teeth	Type	Bush Size	Dp	De	Df	Dm	Di	F	S	Weight kgf
38-14M-170	38	S2F	3030	169.34	167	183	-	130	187	76	11.70
40-14M-170	40	S2F	3030	178.25	175	188	-	140	187	76	13.00
44-14M-170	44	S2F	3535	196.08	193	211	-	155	187	89	15.00
48-14M-170	48	S2F	3535	213.90	211	226	-	175	187	89	19.00
56-14M-170	56	S2F	3535	249.55	247	256	-	210	187	89	28.50
64-14M-170	64	S2F	4040	285.21	282	296	-	240	187	102	41.00
72-14M-170	72	P2	4040	320.86	318	-	230	280	187	102	46.90
80-14M-170	80	P2	4040	356.51	354	-	230	315	187	102	48.00
90-14M-170	90	A2	4040	401.07	398	-	230	360	187	102	52.50
112-14M-170	112	A2	5050	499.11	496	-	265	456	187	127	74.50
144-14M-170	144	A2	5050	641.71	639	-	265	600	187	127	91.00
168-14M-170	168	A2	5050	748.66	746	-	265	706	187	127	116.00
192-14M-170	192	A2	5050	855.62	853	-	265	813	187	127	134.00
216-14M-170	216	A2	5050	962.57	960	-	265	920	187	127	146.50